



myTEM IO Modul
MTIOM-100

The IO module MTIOM-100 is a universal module from myTEM for extending your smart home system with additional inputs and outputs. For this, the device is connected to your central myTEM Smart Server via the CAN bus system.

The programmable behavior allows a flexible use of the device in the house.

Further information can be found on our website:
www.mytem-smarthome.com/web/en/downloads/



ATTENTION:

This device is not a toy. Please keep it away from children and animals!

Please read the manual before attempting to install the device!

These instructions are part of the product and must remain with the end user.

Warning and safety instructions

WARNING!

This word indicates a hazard with a risk that, if not avoided, can result in death or serious injury. Work on the device must only be carried out by persons with the necessary training or instruction.

CAUTION!

This word warns of possible damage to property.

SAFETY INSTRUCTIONS

- Operate this device only as described in the manual.
- Do not operate this device if it has obvious damage.
- This device shall not be altered, modified or opened.
- This device is intended for use in buildings in a dry, dust-free location.
- This device is intended for installation in a control cabinet. After installation, it must not be openly accessible.
- Electrical equipment may only be installed and fitted by qualified electricians who are familiar with and comply with the applicable regulations and standards.
- Analog inputs / outputs, digital inputs, CAN bus and device supply must comply with the ELV requirements. Do not connect ELV and mains voltage together. (ELV = extra-low voltage)
- If several motors are to be connected in parallel at one output, be sure to observe the manufacturer's instructions and, if necessary, use isolating relays. Otherwise the device may be damaged.
- Only use blind motors with mechanical or electronic limit switches. Limit switches must be checked for correct adjustment. Otherwise the device may be damaged.
- Do not connect three-phase motors, the device may be damaged.

DISCLAIMER

All rights reserved. This is a translation from the original version in German.

This manual may not be reproduced in any format, either in whole or in part, nor may it be duplicated or edited by electronic, mechanical or chemical means, without the written consent of the publisher.

The manufacturer, TEM AG, is not liable for any loss or damage caused by failure to follow the instructions in the manual.

Typographical and printing errors cannot be excluded. However, the information contained in this manual is reviewed on a regular basis and any necessary corrections will be implemented in the next edition. We accept no liability for technical or typographical errors or the consequences thereof. Changes may be made without prior notice as a result of technical advances. TEM AG reserves the right to make changes to product design, layout and driver revisions without notice to its users. This version of the manual supersedes all previous versions.

Trademarks

myTEM and TEM are registered trademarks. All other product names mentioned herein may be trademarks or registered trademarks of their respective companies.

Applications:

- Switching of lights
- Switching of single-phase fan motors
- Switching of electric blinds or similar shading devices
- Operation by means of buttons, sensors via the central server

Functions:

- Supply voltage 24 VDC ± 10% with support terminals for further wiring
- CAN bus
- 12 digital inputs 24 VDC (DI1 – DI12) for e.g. external switches
- 2x 24 VDC power supply, 100 mA, for digital inputs DI1 – DI12 (VDIout)
- 4 analogue inputs 0-10 VDC (AI1 – AI4). AI1 and AI2 can also use NTC, PTC or PT1000 sensors. All analog inputs can also be used as digital inputs 24 VDC. They must then be connected to VDIout.
- 4 analogue outputs 0-10 VDC, 20 mA (AO1 – AO4)
- 8 digital outputs with potential-free relays 8 A, 250 VAC or 30 VDC (DO1 – DO8)
- Manual positions of the outputs via DIP switch for easy commissioning
- The device is installed in a control cabinet, mounted on a 35 mm DIN rail

Installation

WARNING! Depending on national safety standards, only authorized and/or trained technicians may be allowed to perform electrical installations on the power grid. Please inform yourself about the legal situation before installation.

WARNING! Different voltages (e.g. 24 VDC, 230 VAC L1 or 230 VAC L2) may only be connected to the digital outputs (relays) **if one output is left out between them.**

Please install the device according to the following steps:

- WARNING!** Make sure that the device is disconnected from the power supply or that the devices in the control cabinet are disconnected from the mains.
- WARNING!** Connect the device according to the circuit diagram of the myTEM ProgTool or the terminal assignment from the picture above. Incorrect wiring can result in injury or death or damage the device.
- CAUTION!** The device shall only be operated with stabilized power supplies (24 VDC). Connecting to higher voltages will damage the device.
- The last device on the CAN bus requires the terminating resistor of 120 Ω **enclosed with the myTEM Smart Server** via terminals (CAN +/-).
- WARNING!** Switch on the power supply and, if necessary, check the wiring with the manual positions via the DIP switch. **Take care of your safety as the devices are live.**

Manual positions via DIP switch

With the aid of the DIP switch, the outputs can be checked after installation.

- CAUTION!** While manual settings are used, the control commands from the myTEM Smart Server or myTEM Radio Server are ignored.
- CAUTION!** Before starting, set all DIP switches to position OFF, i.e. upwards. This avoids that e.g. OPEN / CLOSE commands are set at the same time.
- To check the digital outputs (relays) set DIP switch 10 down to ON. With the DIP switches 1 - 8 you can now switch the relays DO1 - DO8 on and off.
- To check the analog outputs set DIP switches 9 and 10 down to ON. With the DIP switches 1 - 4 you can now set the analog outputs AO1 - AO4 from 0 VDC (position OFF) to 10 VDC (position ON).

Behavior after power failure

After a power failure, all outputs are switched off until the new settings are received from the myTEM Smart Server or myTEM Radio Server.

LED display

The LED next to the CAN connector may show the following states:

- LED green:** Device started and connection to the myTEM Smart Server or myTEM Radio Server working
- LED flashing green:** Device is in manual position
- LED red:** Device started but no connection with the myTEM Smart Server or myTEM Radio Server
- LED off:** Device not powered, not started or broken

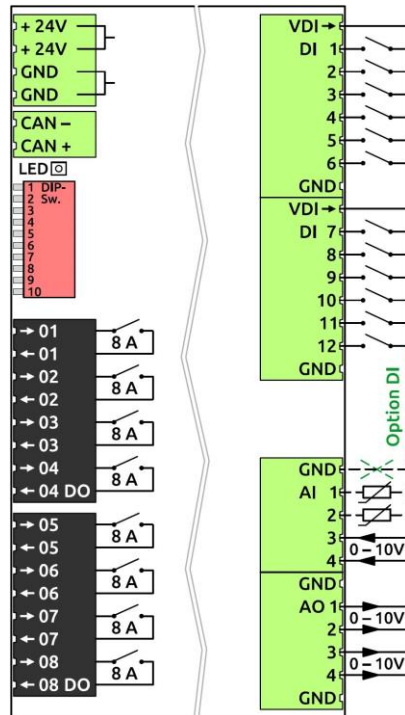

Quick trouble shooting

The following hints may help solving trouble:

- Make sure that the power supply is connected with the correct polarity. With wrong polarity the device does not start.
- If a device cannot establish communication to the myTEM Smart Server or myTEM Radio Server, check if the CAN bus (+/-) is correctly wired and the ground (GND) is connected. A missing ground connection (usually available via power supply) can affect the communication.
- If a device cannot establish communication to the myTEM Smart Server or myTEM Radio Server, check whether the terminating resistor of 120 Ω at the last device is connected to the CAN bus. If missing, please add it via terminals (CAN +/-).

Configuration

The products can be used immediately after being added to the Smart Home network. However, depending on the function, a configuration may be helpful or required. After setting the parameters, further optional corrections such as offset, etc. are sometimes possible.

CAUTION! Depending on the function, the server may change some settings.

Description	Settings					
Analog inputs	Analog 0 – 10V	Digital	NTC 5k	NTC 10k	PT 1000	PTC (KTY81/110)
Analog outputs	0 – 100%		0 – 10V			

Technical specifications

Dimensions (W x H x D)	160.5 x 101.1 x 62.5 mm (height with connectors 106.8 mm)	
Installation / mounting	On 35 mm DIN rail	
Operating voltage	24 VDC ± 10%	
Power consumption in standby	Device for continuous operation, no standby mode	
Power consumption in operation	0.4 W, if the inputs are open and the outputs are turned off 4.5 W, if the inputs are short-circuited to VDIout and the outputs are turned on	
Switchable load	8x 8 A, 250 VAC or 30 VDC, cos(φ) = 1.0; minimum switchable load 300 mW (5 VDC, 5 mA) WARNING! The maximum current across all relays must not exceed 48A	
Analogue outputs	4x 0-10 VDC, 20 mA	
Power supply for digital inputs	2x 24 VDC, 100 mA	
Ambient temperature for operation	0 °C – 50 °C	
Ambient temperature for storage	-20 °C – 60 °C	
Ambient humidity	5 %RH – 85 %RH (non condensing)	
Wire cross-section connectors	0.25 mm ² – 2.5 mm ²	
Stripping length for connectors	ca. 7 mm	
Tightening torque for connectors	0.5 Nm	
Degree of protection provided by enclosure	IP 20 (after installation)	(according to EN 60529)
Protection class	II	(according to EN 60730-1)
Overvoltage category	II	(according to EN 60730-1, resp. EN 60664-1)
Pollution degree	2	(according to EN 60730-1)
Electrical safety	EN 60730-1:2016 + A1:2019	EN IEC 60730-2-9:2019 + A1:2019
EMC	EN 60730-1:2016 + A1:2019 EN IEC 61000-6-2:2019	EN IEC 60730-2-9:2019 + A1:2019 EN 61000-6-3:2007 + A1:2011 / AC:2012
RoHS	EN IEC 63000:2018	
CE conformity	2014/35/EU (LVD) 2014/30/EU (EMC)	2011/65/EU (RoHS)

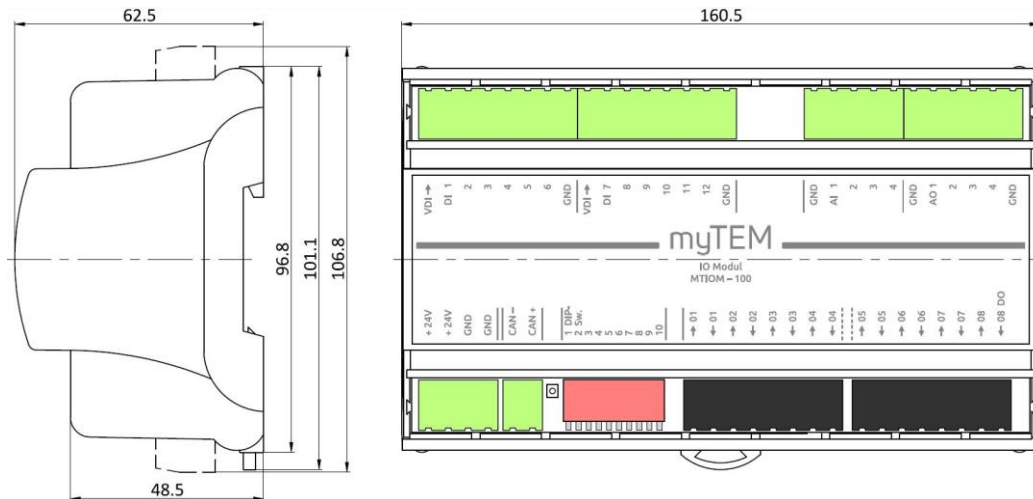

Belegungsplan / Assignment plan / Plan d'affectation / Piano di assegnazione

